

Vibrational Energy harvesting: State of the Art

Markys Cain
National Physical Laboratory

Outline

- Energy harvesting
- Where\why would you use energy harvesting
- Energy conversion techniques
 - Covering mechanical – electrical conversion, not solar
- Energy harvesting sources
- Energy harvesting from human sources
- Vibration energy harvesting
 - Macro Scale
 - MEMS scale
- NPL - metrology
- Conclusions

Why use energy harvesting ?

- Save energy, save the planet – not really
 - Amount of energy relatively small
- Free energy, save money – not really
 - Device costs likely to cost more than energy used/saved.
- Wireless
 - Save wiring looms, in buildings, in automobiles
- No battery
 - More environmentally friendly
 - No need to replace batteries – maintenance free
 - Underwater, in-vivo, remote locations
- Energy Density
 - Distributed Wireless Sensors

Energy Harvesting – energy conversion techniques

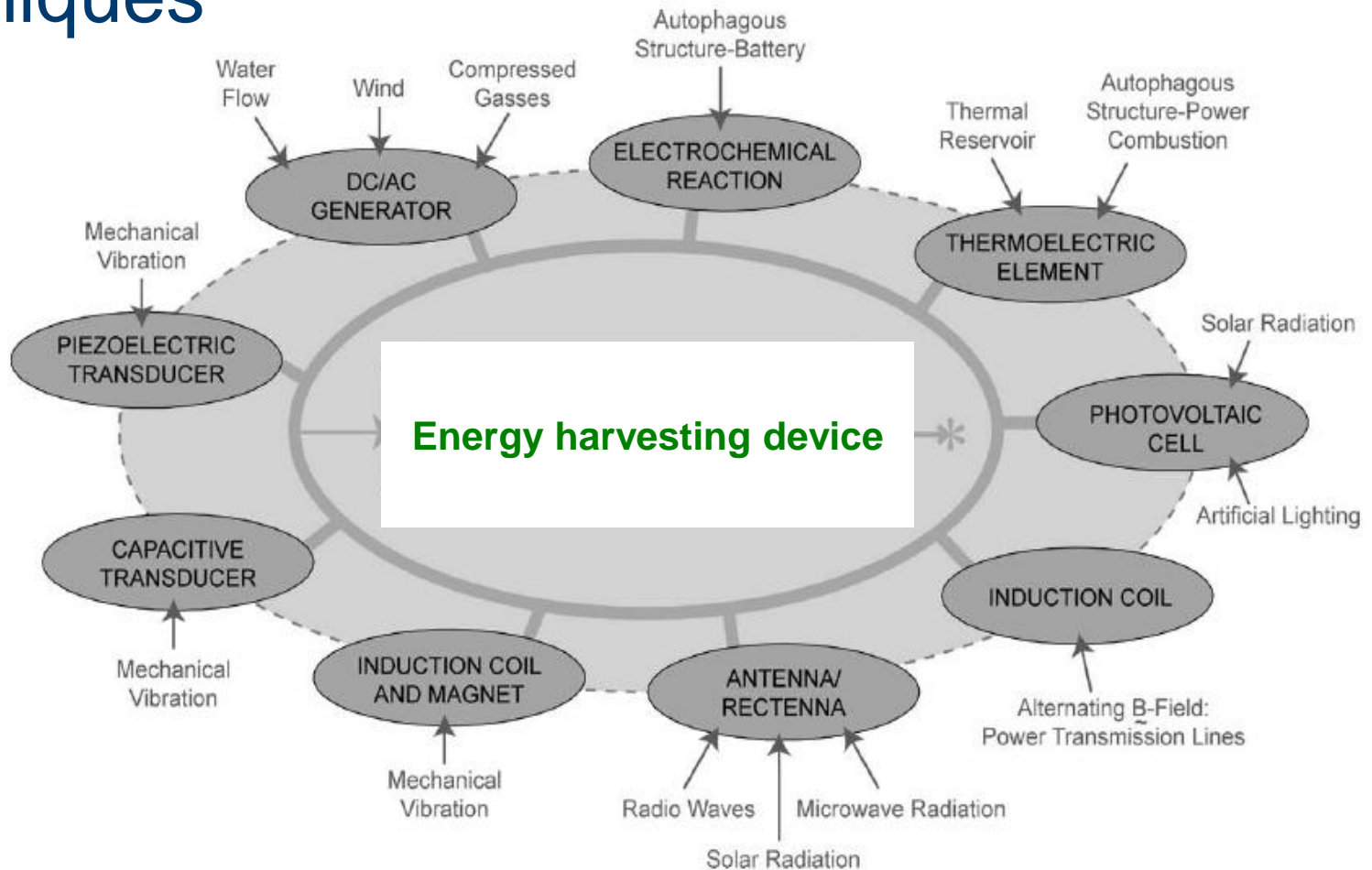

Energy density comparison for selected sources

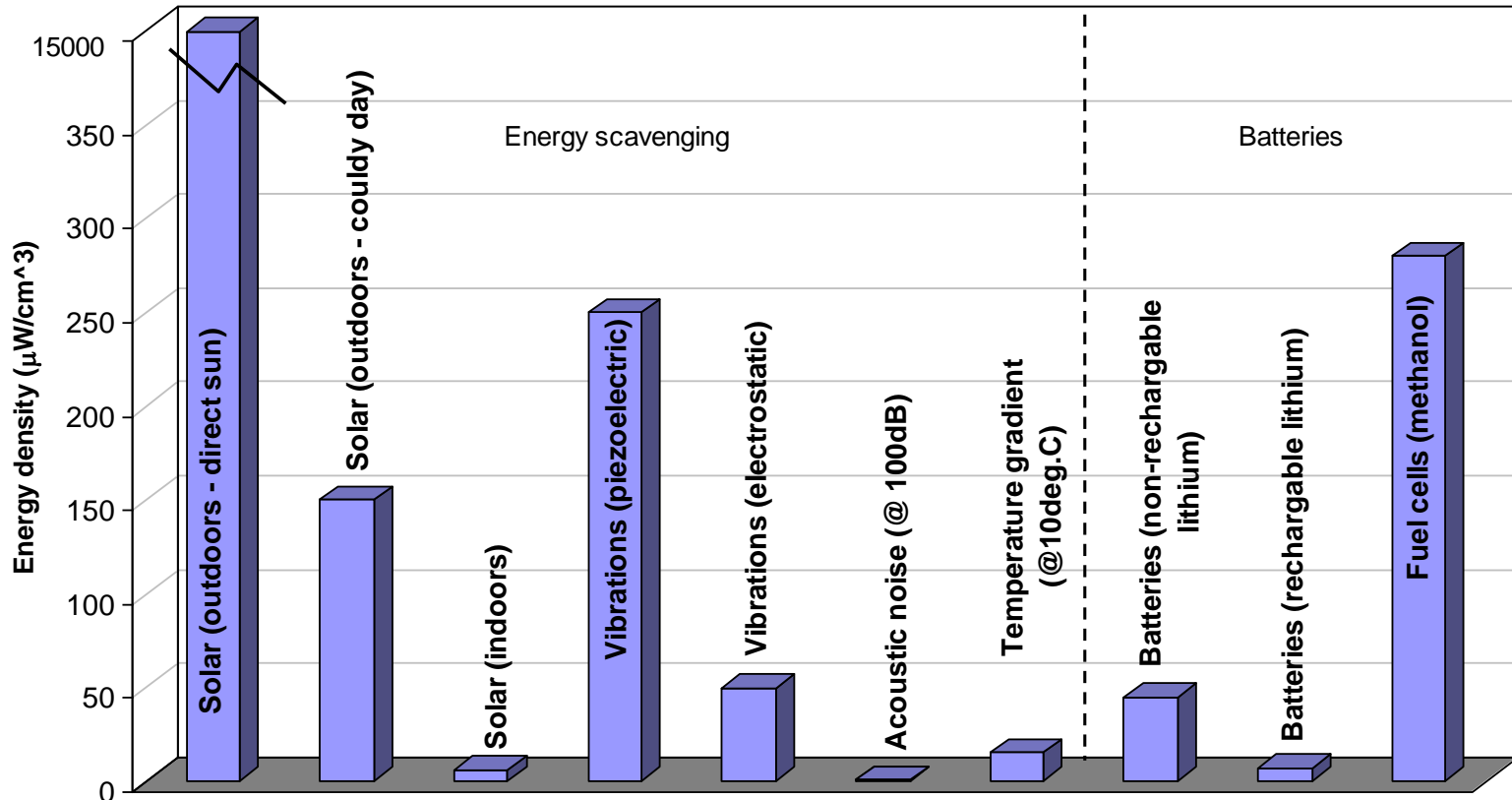

Energy density comparison for selected energy sources*

*) based on Shad Roundy, Paul K. Wright, Jan Rabaey, "A study of low level vibrations as a power source for wireless sensor nodes", Computer Communications 26 (2003) 1131-1144

Energy Harvesting from the body

Inertial Devices

Electromagnetic Scavenging

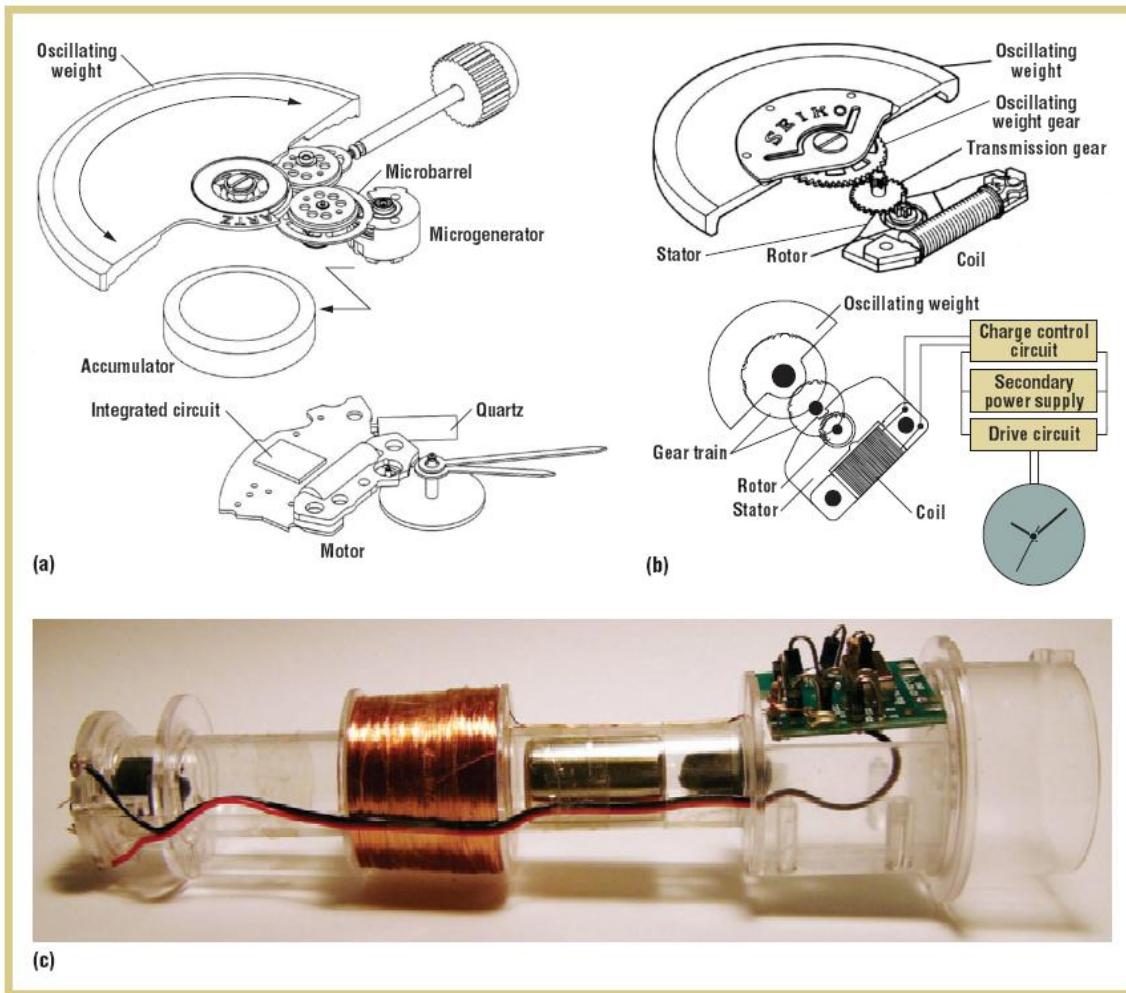
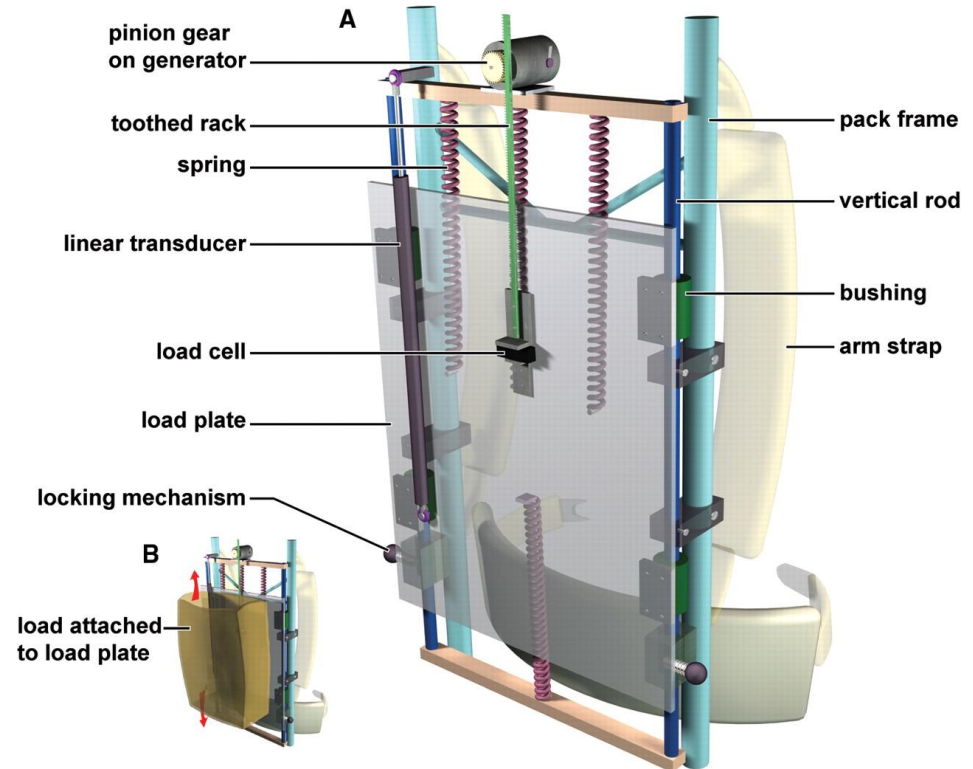
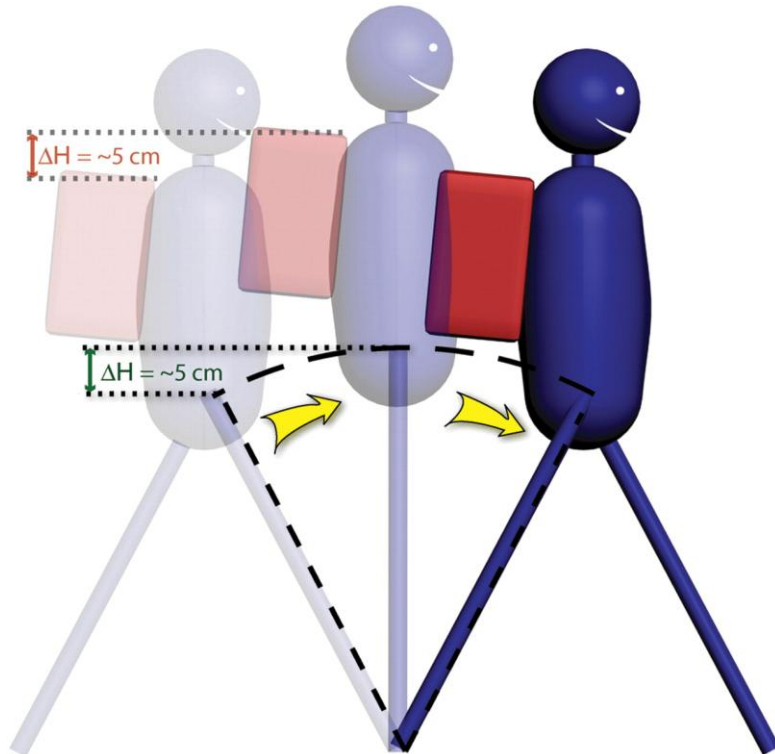

Figure 3. Commercial inertial-power scavengers. Two mechanisms for self-winding electric watches—(a) the ETA Autoquartz design

- An oscillating weight (selfwinding mechanism in a traditional watch) transmits the mechanical energy to the micro-generator through the microbarrel.
- The generator converts this mechanical energy into electrical energy and stores it in an accumulator.

Energy Harvesting Backpack

- Electromagnetic generator
- Max Output ~ 7W
- Carrying 38kg



Energy Harvesting from the body

Direct Force Devices

Energy harvesting from Walking

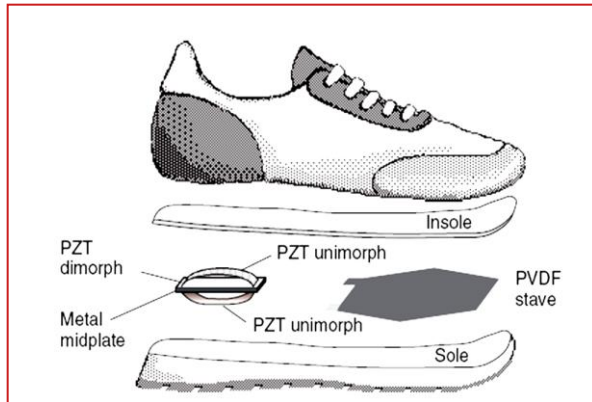

Shoe-mounted energy scavenger*

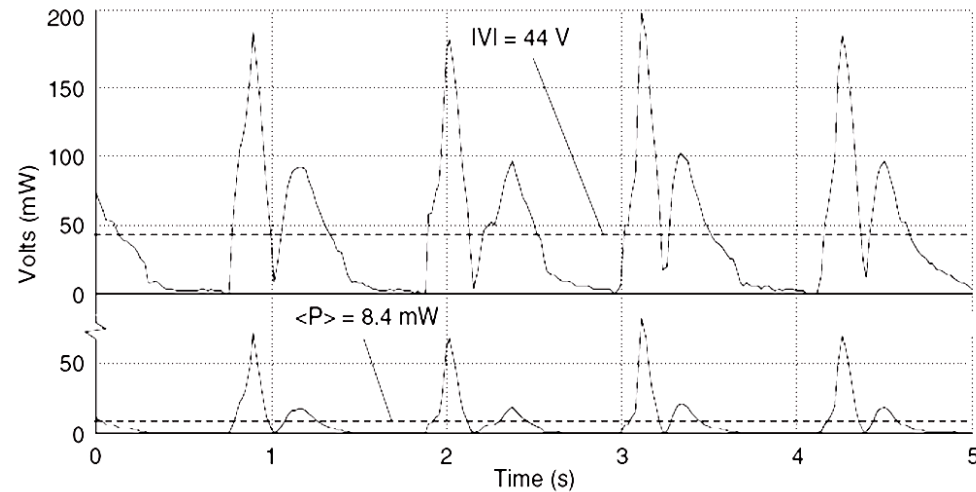

Example of the generated voltage and power*

**) Nathan S. Shenck, Joseph A. Paradiso, "Energy Scavenging With Shoe-Mounted Piezoelectrics", Publications IEEE, 2001*

Electromagnetic Remote Transmitter

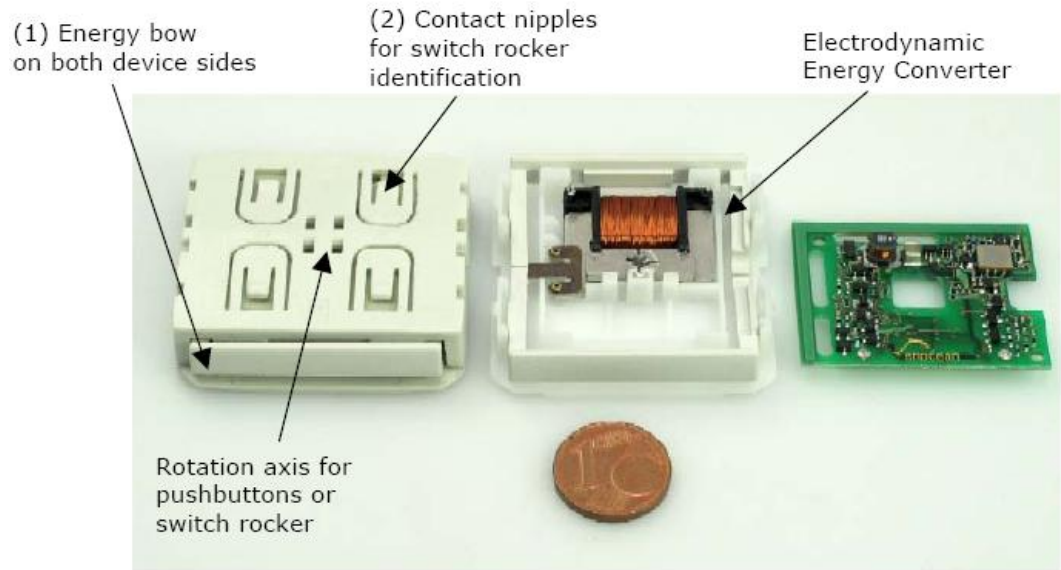
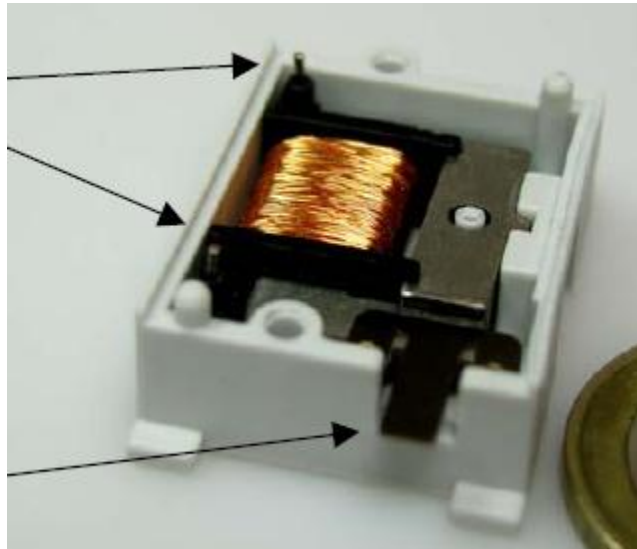

Mechanical dimensions: 33.3 x 22.0 x 10.8 mm
Actuating force / travel: 2.1±0.5 N / 2.0 mm
Switching cycles (up or down): >60.000 at 25°C
Operating temperature: +5 up to +65 °C
Output pulse: T (rise time) Typical 1,4 ms
Output pulse: U_{END} (voltage in the capacitor at the end of the energy pulse) Typical 5 V ± 25%

<http://www.enocean.com/>

Piezoelectric Remote Transmitter



**NASA
Piezoelectric
Material**

**Face
Electronics**



**Lightning
Transmitter**

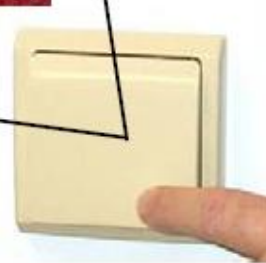

Lightning Switch
wireless
Transmitters (what
look like the
switches) use
NASA space
technology to
generate their own
electricity
whenever the
Transmitter button
is pushed.

<http://www.lightningswitch.com/>

Energy Harvesting: Direct Force Device

Piezoelectric powered Tyre Sensor



Attached inside tyre



Transmits Data to Dashboard

Harvesting Vibrational energy from Rainwater



“The corresponding instantaneous converted power starts from a few μW up to 10 mW for a converter area of a several square centimeters. An interesting figure to keep in mind could also be the available rain power per year in common France regions with a continental climate: almost 1 Wh per square meter per year”

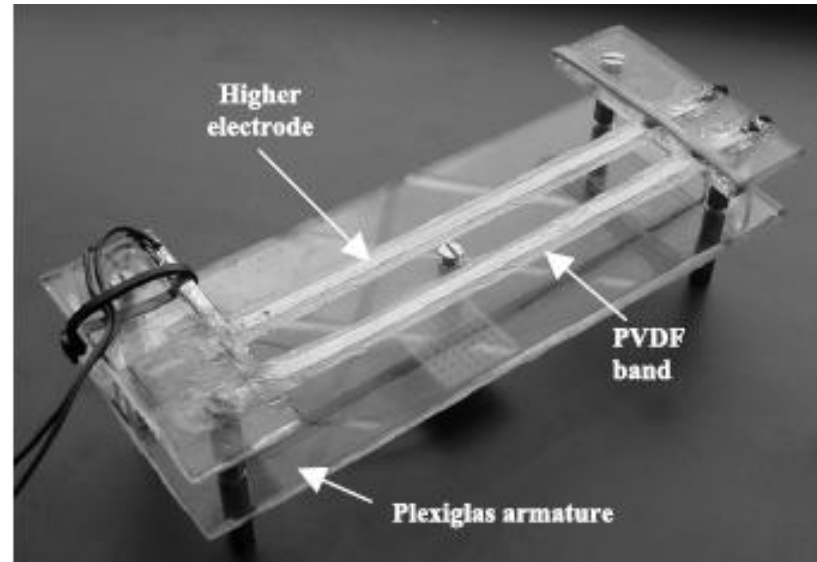

CEA-LETI-MINATEC

Vibration Energy Harvesting

Electromagnetic Vibration energy harvesting

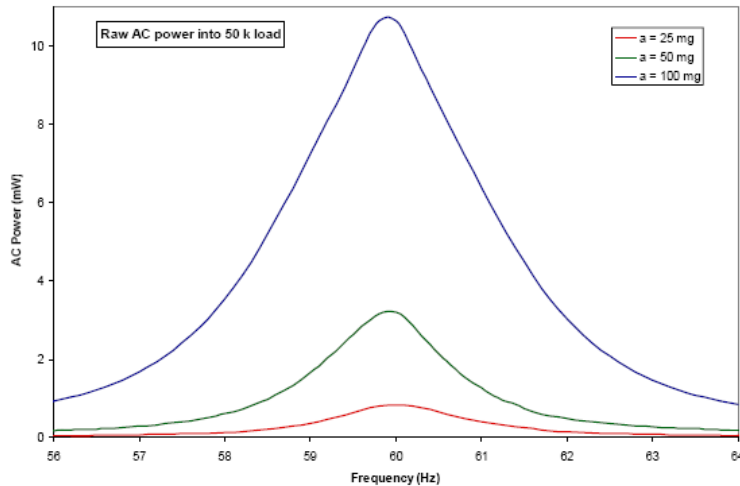

POWER OUTPUT @ 60 HZ (raw AC from generator)

Acceleration	25 milli-g	0.8 mW
	50 milli-g	3.1 mW
	100 milli-g	10.8 mW

BANDWIDTH ($\Delta f = 2.1$ Hz)

Peak frequency	60 Hz
50% power delivered	+/- 1.5 Hz
Q	28

DIMENSIONS

Height	1.52 in	39 mm
Diameter	2.59 in	66 mm
Mass	10.2 oz	289 g



<http://www.ferrosi.com>

PME – piezo magnetic system

Piezoelectric vibration energy harvester (Volture)

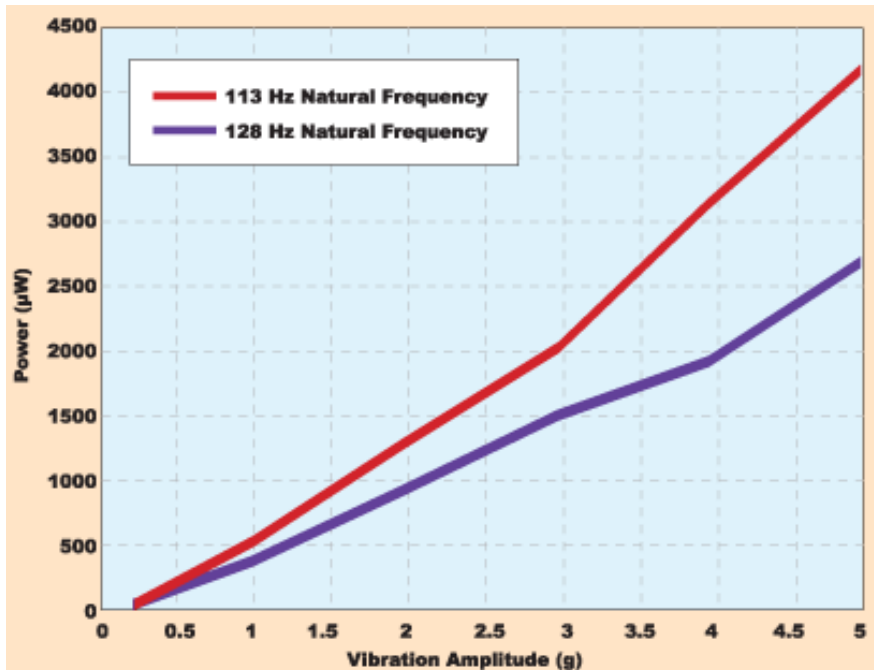
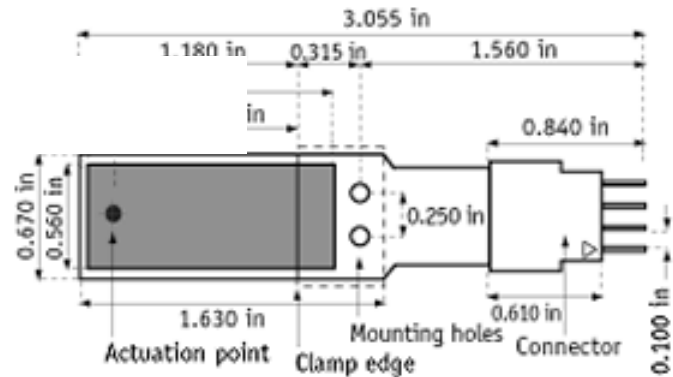
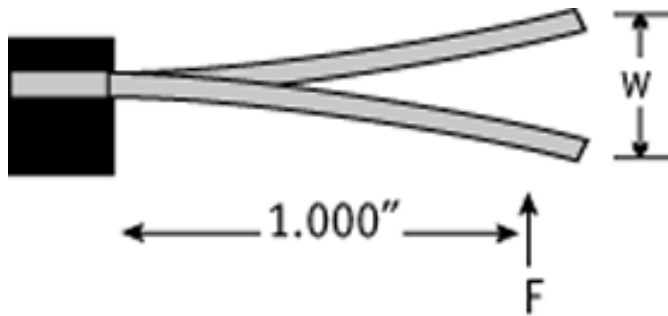

Device size (in): 3.625 x 1.725 x 0.39

Device weight (oz): 2 oz



www.mide.com

Piezoelectric vibration energy harvester (Joule Thief)

ADAPTIVE ENERGY HARVESTING DEVICES
(Power versus Acceleration)

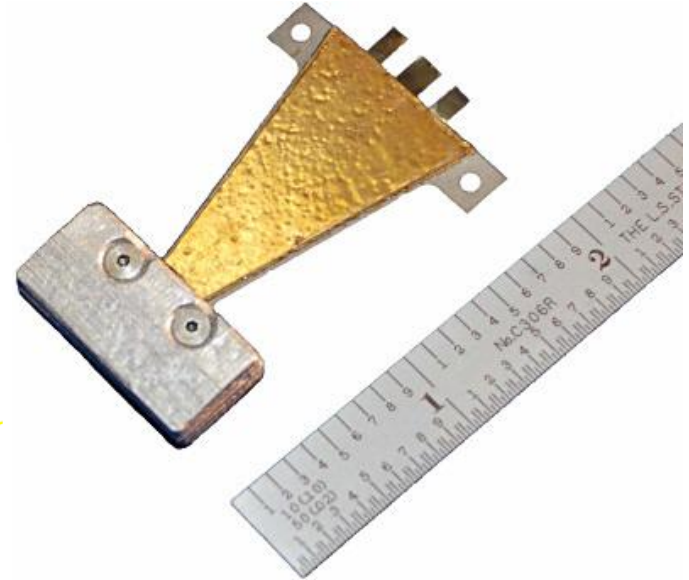
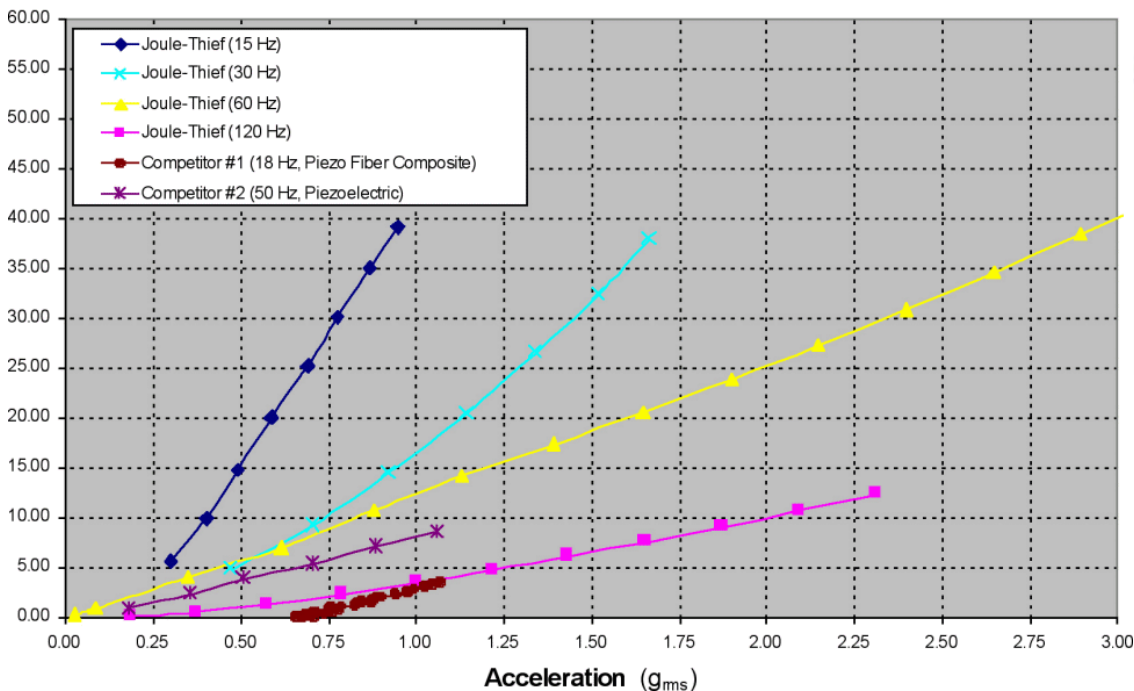

www.rlpenergy.com

Claim “ *the highest output per unit volume energy harvester in the world.*”
(40mW)

Microscale Vibration Energy Harvesting

$$\text{Power} = m\omega^3 Y_0 z_0 / \pi$$

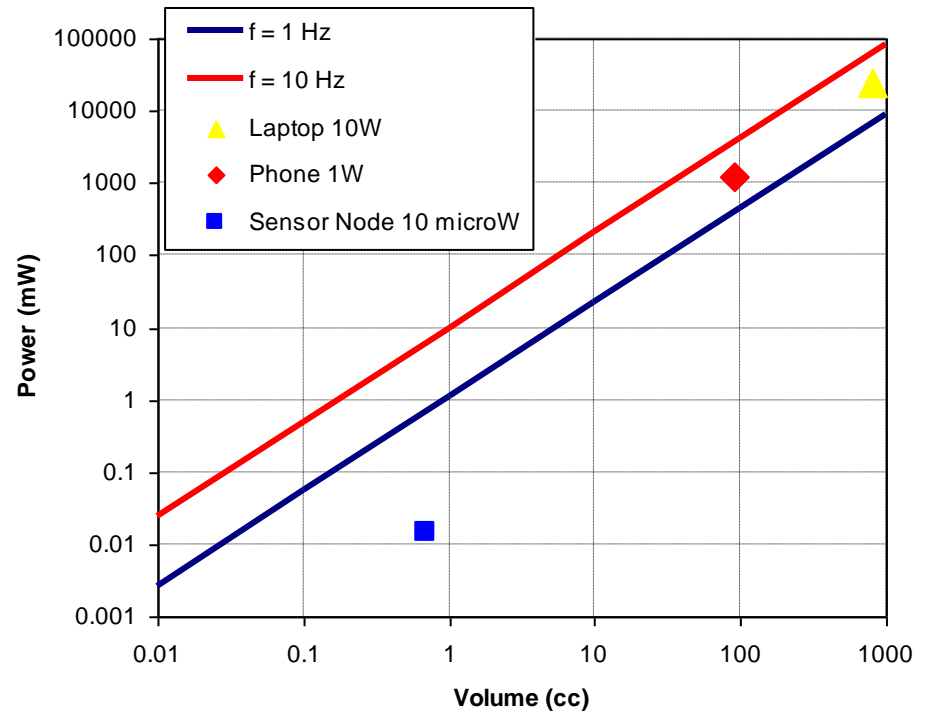
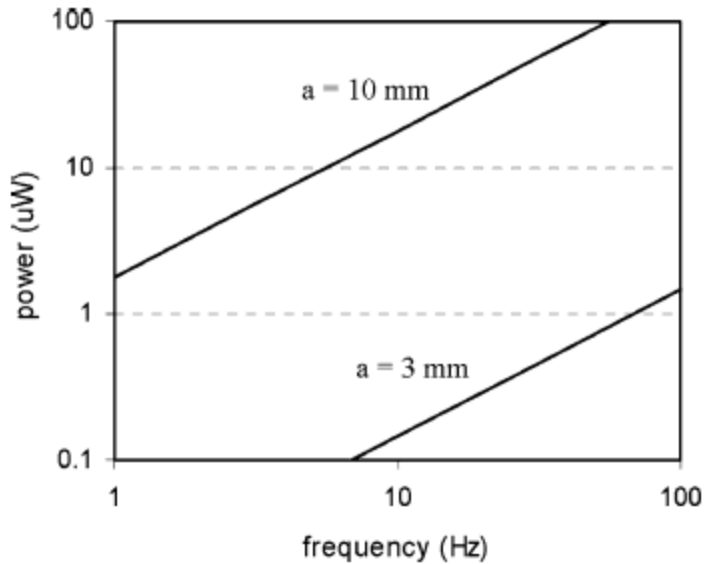
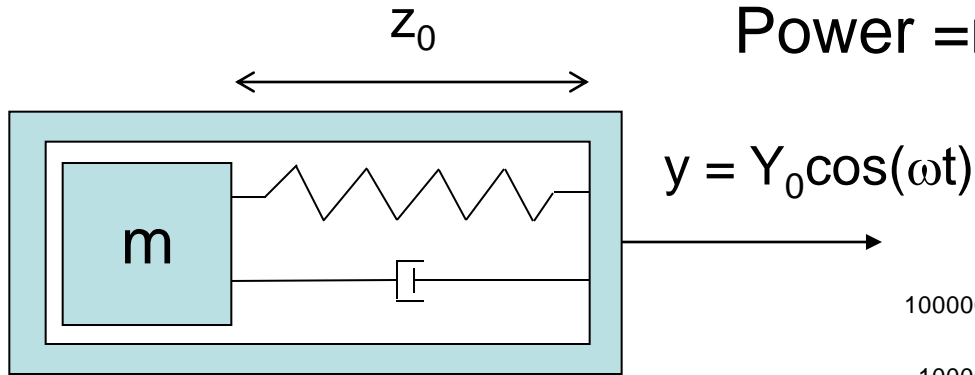
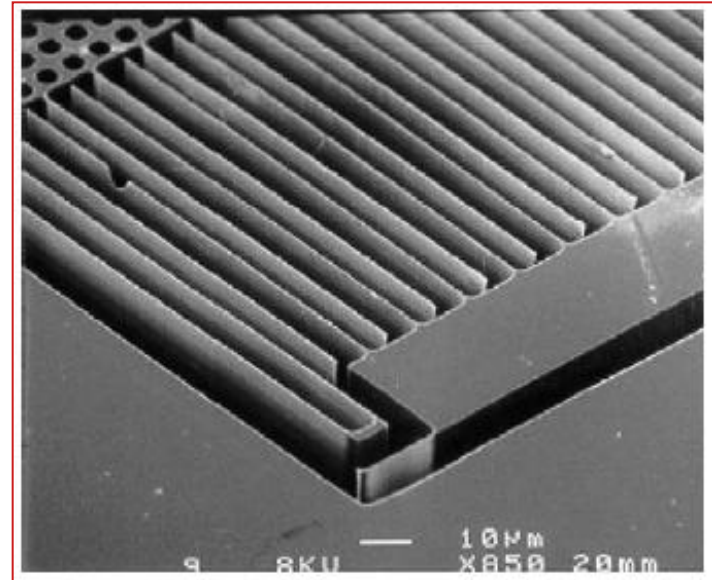
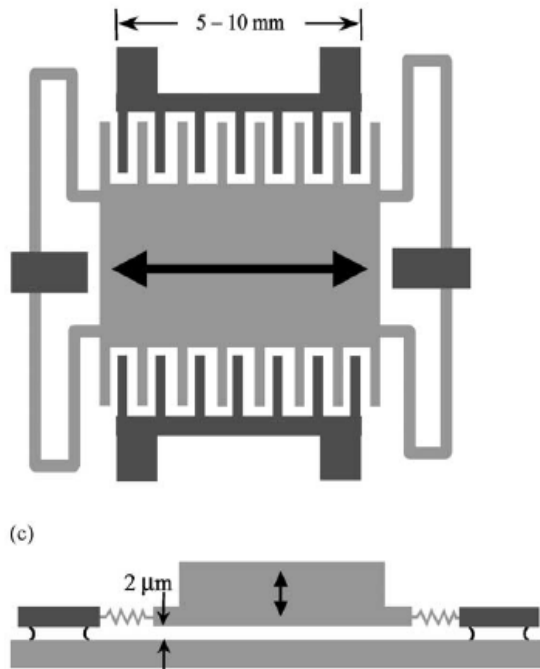

Fig. 7 Maximum output power versus frequency, for dimensions as indicated

MEMS Electrostatic scavengers

- A relative movement between electrically isolated charged capacitor plates is utilised. The work against the electrostatic force between the plates provides the harvested energy.
- Typically optimised for resonant operation.



Shad Roundy, Paul K. Wright, Jan Rabaey, "A study of low level vibrations as a power source for wireless sensor nodes", *Computer Communications* 26 (2003) 1131–1144'

EC project Vibration Energy Scavenging ('VIBES')

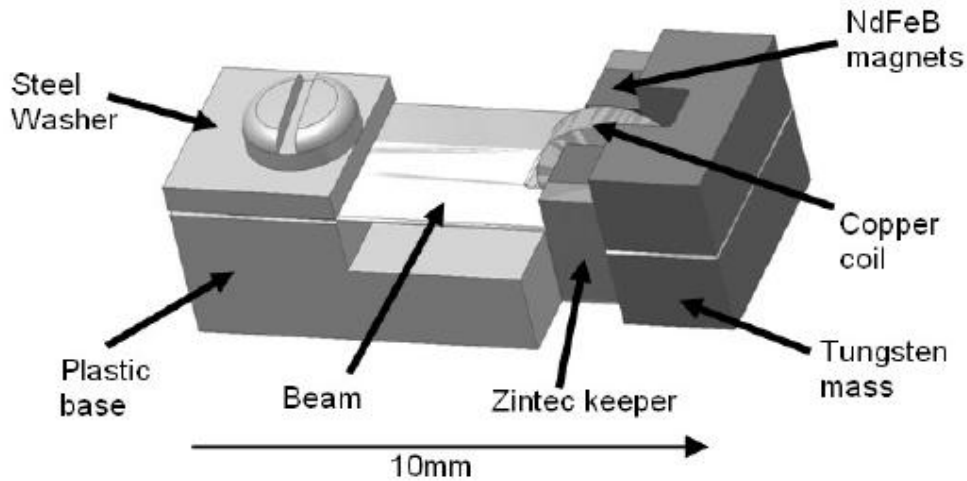

Magnetic energy harvesting focus
(Piezo harvesting)

<http://www.vibes.ecs.soton.ac.uk>

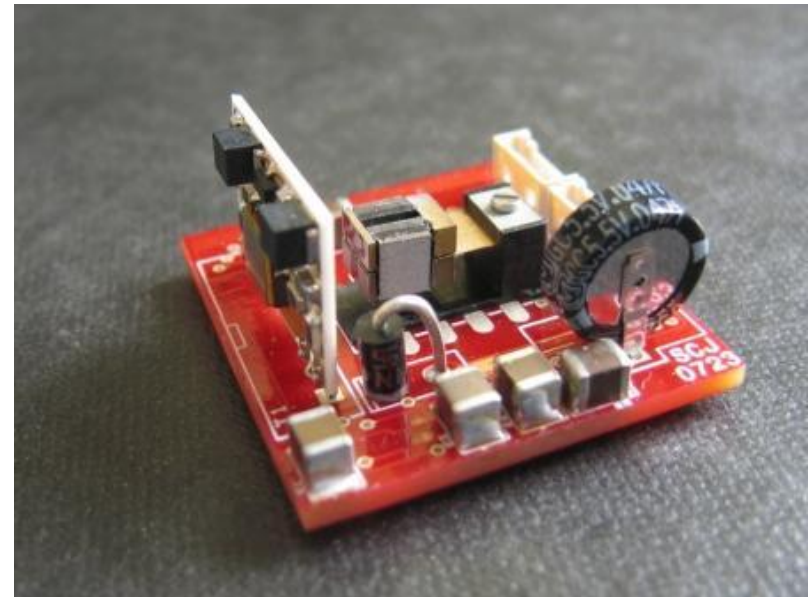
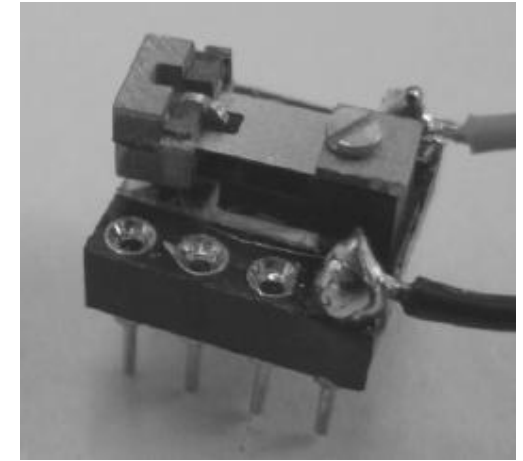

Piezoelectric MEMS scavengers

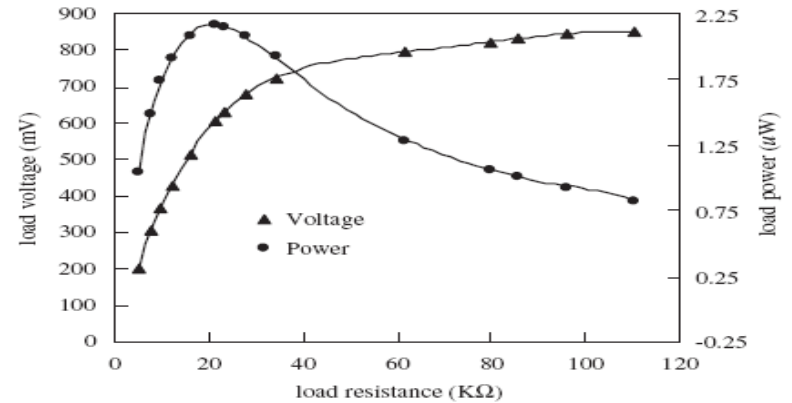
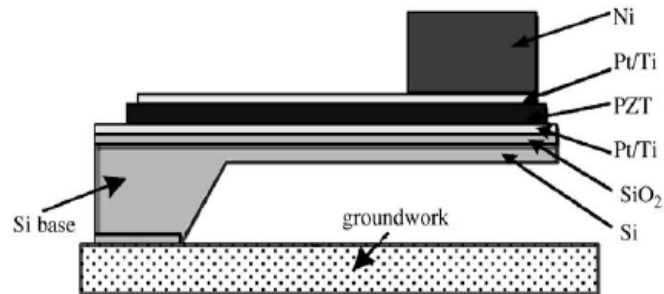

An example of MEMS piezoelectric scavenger*

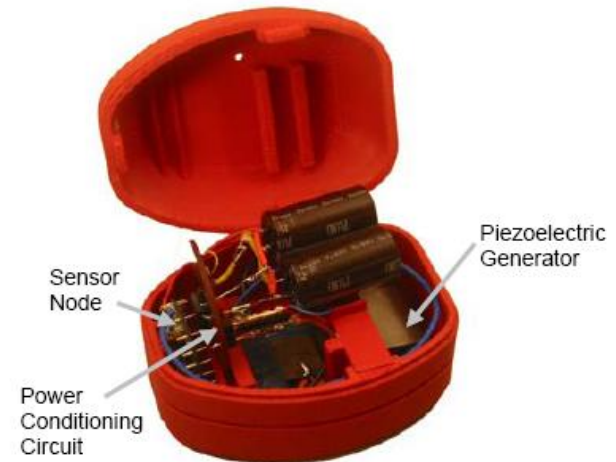

*) Hua-Bin Fang, Jing-Quan Liu, Zheng-Yi Xu, Lu Dong, Li Wang, Di Chen, Bing-Chu Cai, Yue Liu, *Fabrication and performance of MEMS-based piezoelectric power generator for vibration energy harvesting, Microelectronics Journal 37 (2006) 1280–1284*

Eli S. Leland, Elaine M. Lai, Paul K. Wright Berkley

NPL role in characterising energy harvesting devices

Characterising the vibration environment

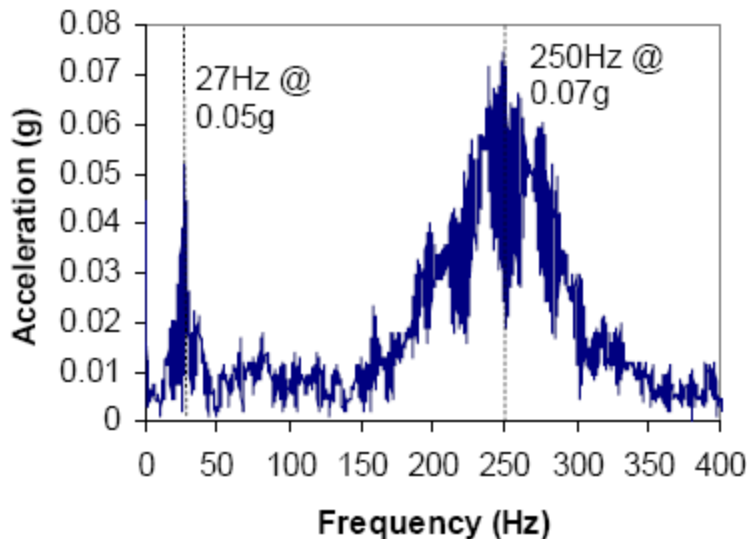

Fig. 3: Frequency Spectrum Analysis of Staircase Vibrations

Vibration source	A (m/s^2)	F_{peak}
Car engine compartment	12	200
Base of 3-axis machine tool	10	70
Blender casing	6.4	121
Clothes dryer	3.5	121
Person nervously tapping their heel	3	1
Car instrument panel	3	13
Door frame just after door closes	3	125
Small microwave oven	2.5	121
HVAC vents in office building	0.2–1.5	60
Windows next to a busy road	0.7	100
CD on notebook computer	0.6	75
Second story floor of busy office	0.2	100

NPL role in characterising energy harvesting devices

Simulation of the environment for testing



Parameters to investigate

- Electrical load on the device
- Operation off resonance
- Operation with different stimuli
- Amplitude

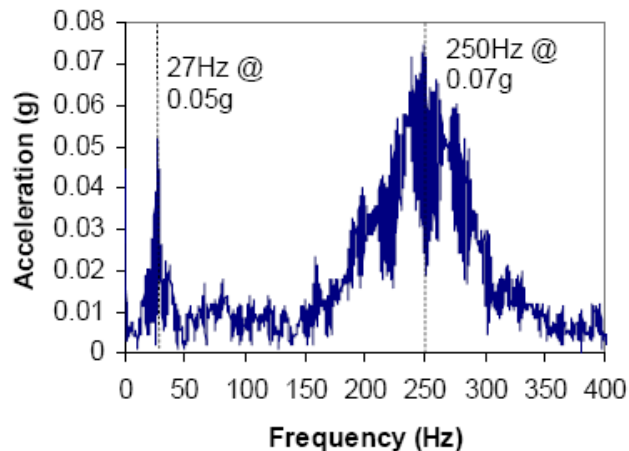
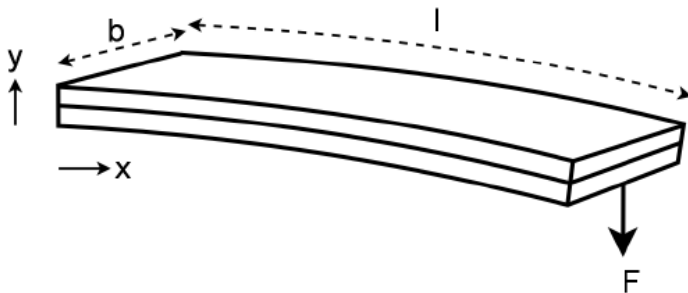
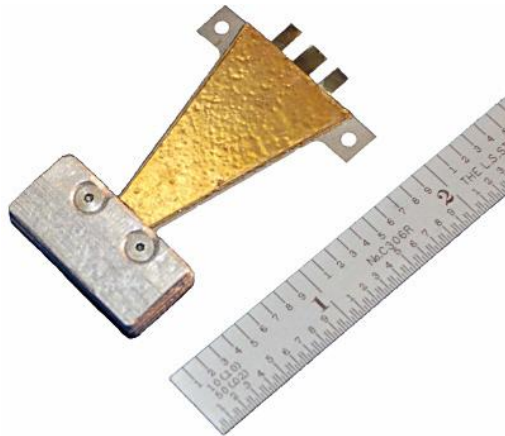

Fig. 3: Frequency Spectrum Analysis of Staircase Vibrations

NPL role in characterising energy harvesting devices

Piezoelectric Material Effects



Parameters to investigate

- Piezoelectric is also a capacitor
 - balance strain between and capacitance of device
- Modelling expected output
 - scaling laws
 - non linearity of piezoelectric response
 - Processing factors, residual stress, adhesive bonds

$$Q = -\frac{d_{31}E_2wl^2F}{2EI}(y_c - \bar{y}) \quad V = -\frac{d_{31}E_2lt_2F}{2EI\epsilon_0\epsilon_{33}}(y_c - \bar{y})$$

Roadmap for Energy Harvesting (source WTC)

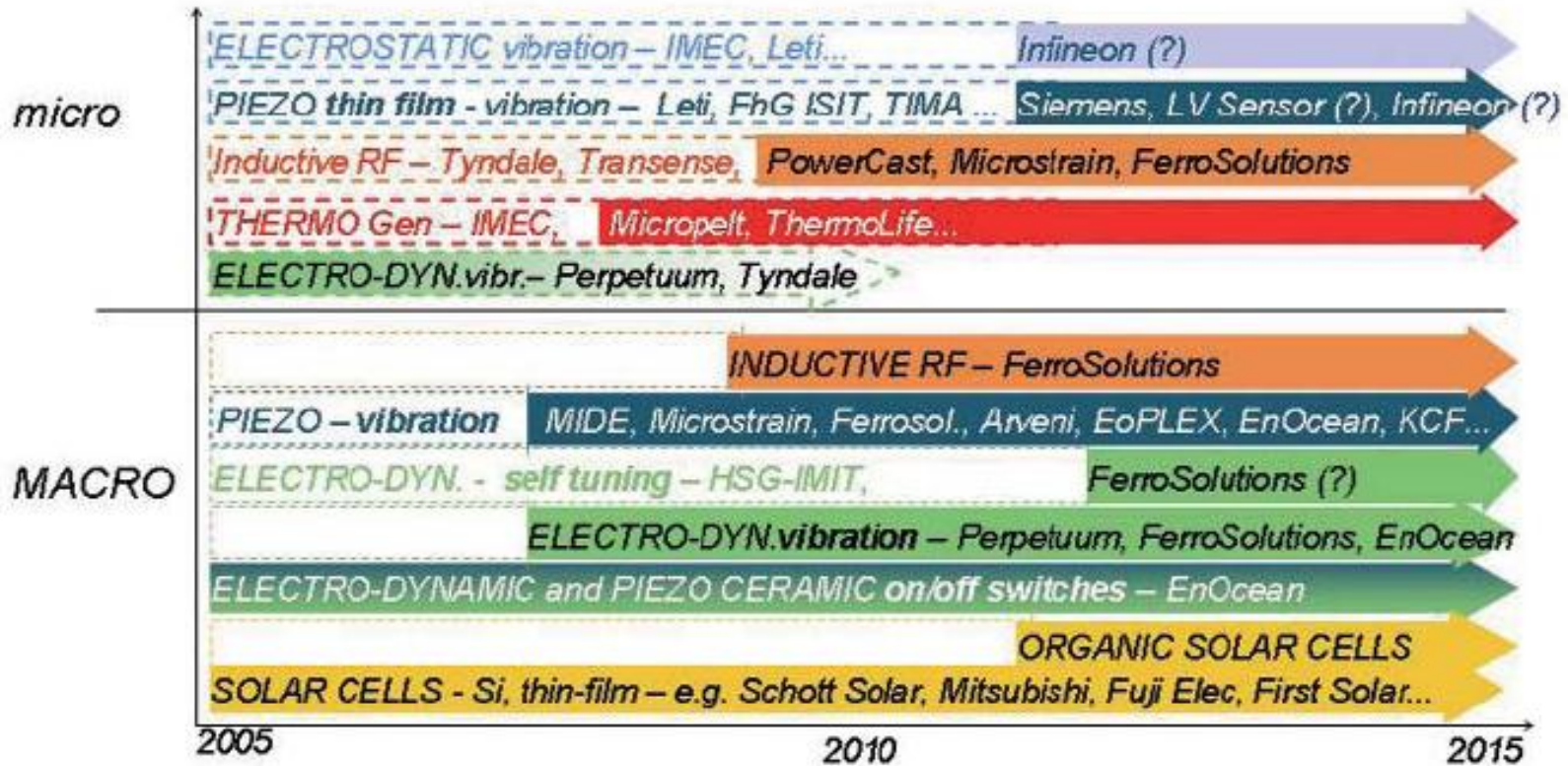

Source: WTC

Future for energy harvesting in TPMS

(source WTC)

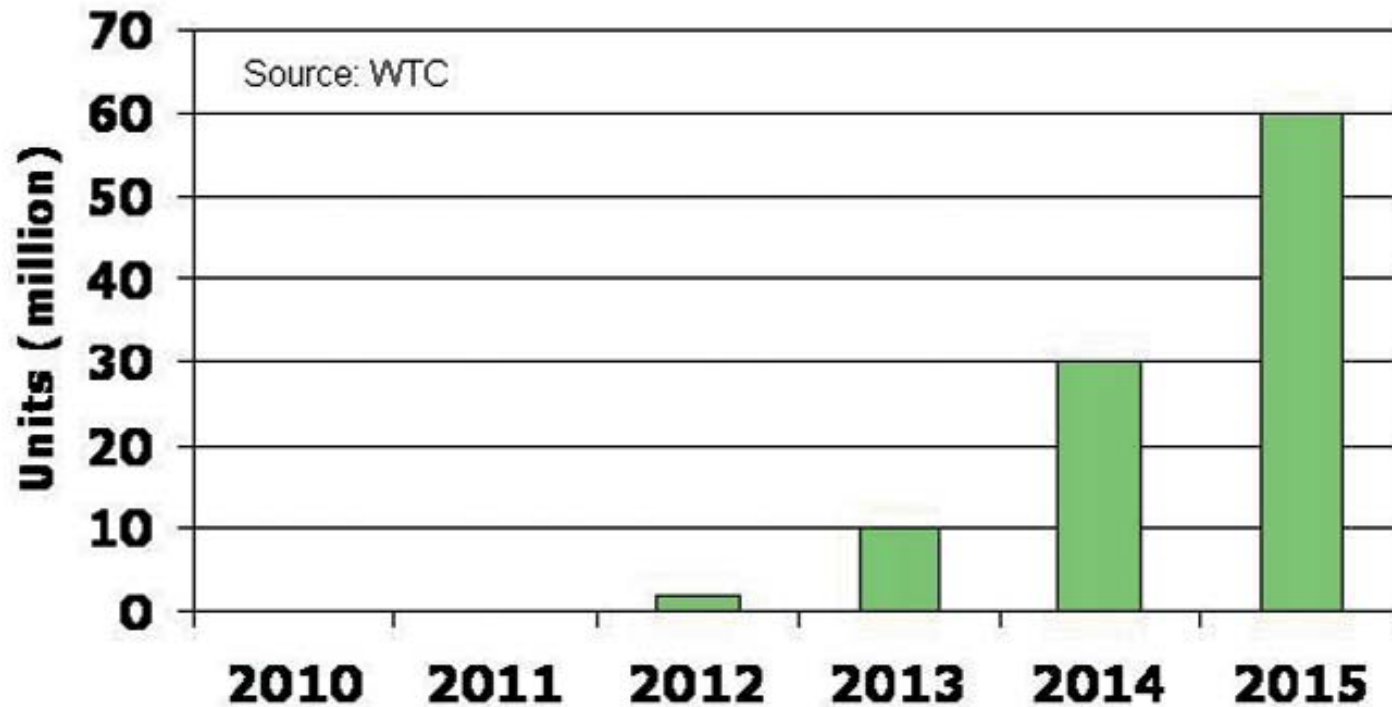

Summary

- Expectations of energy harvesting must be realistic.
- Energy Harvesting Devices are already commercially available.
- Reduction of power requirements, particularly for wireless technologies has increased the opportunities for energy harvesting.
- MEMS devices not yet realised – but TPMS most promising application
- Piezoelectric based energy scavengers offer very good performance in comparison to the other techniques especially in microsystem applications. But integration challenge!

Acknowledgements

- Funding from UK's National Measurement System
- Thanks to our Industrial Advisory Group
- Resource and support from the Piezo Institute
- NPL Multifunctional Materials Group:
 - Notably Mark Stewart & Paul Weaver



- Electronics KTN
- Thanks for listening and the opportunity to discuss our work